

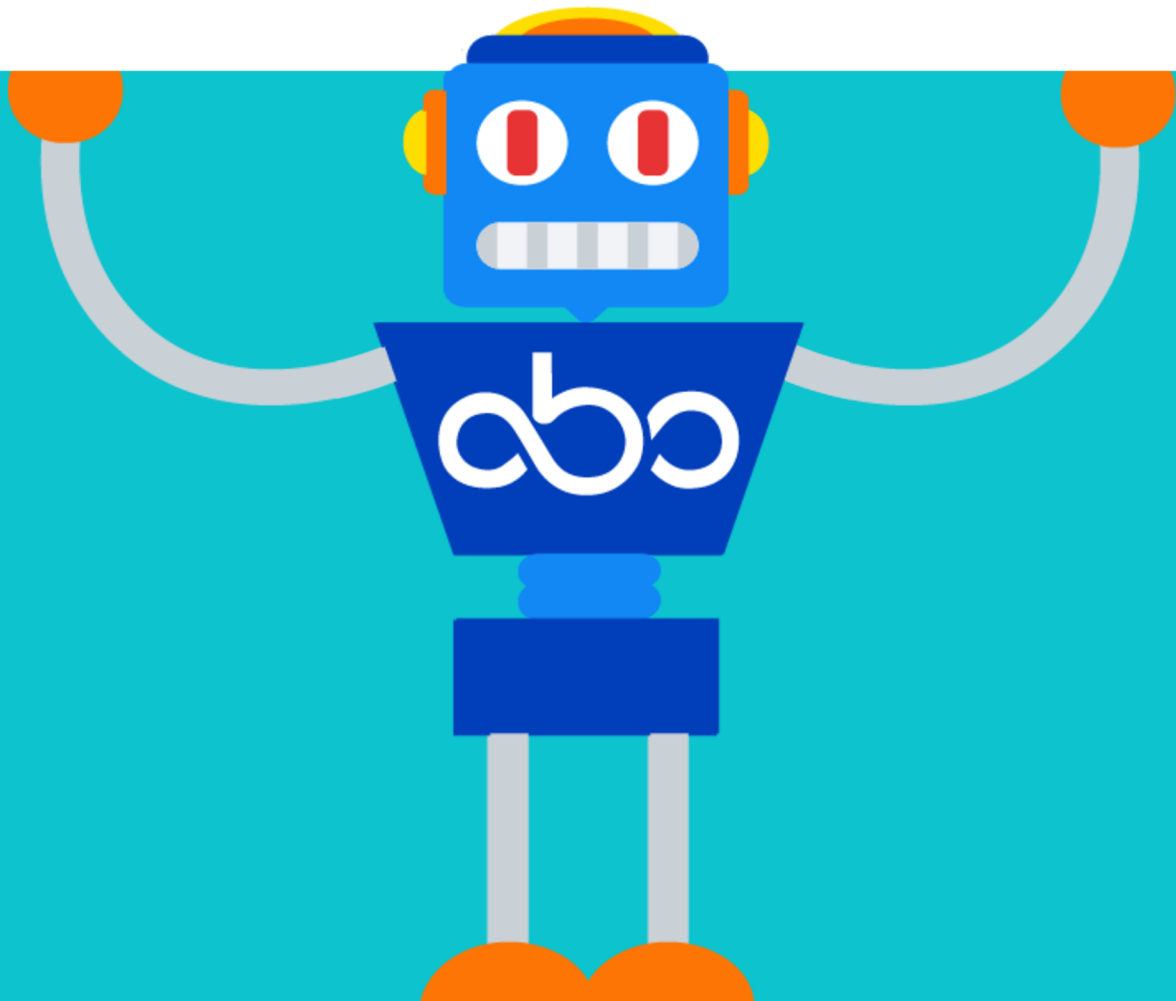

EU FOR ALL

Using Sustainable Entrepreneurship to Rebuild European Heritage for All

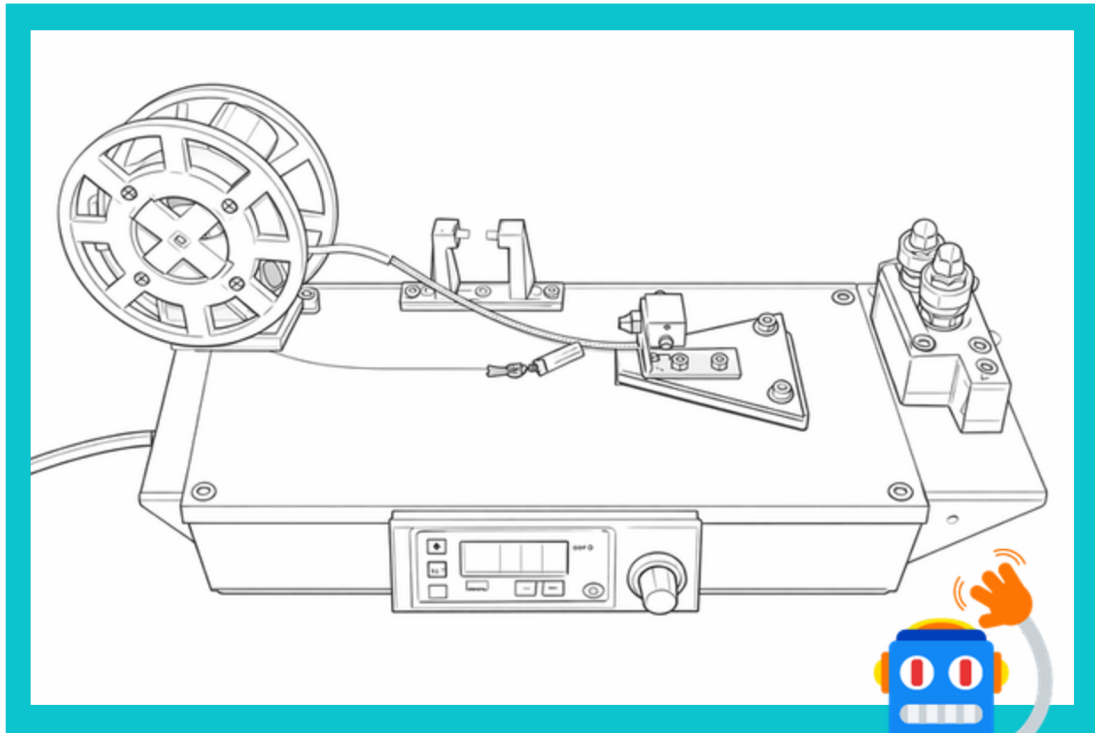



FROM PLASTIC TO FILAMENT

**PET BOTTLE
RECYCLER .STL
FILES**



The resources of the EU FOR ALL project, including the materials kit, 3D models, and educational proposals, are undergoing continuous improvement. We are constantly working to incorporate new ideas, adjustments, and contributions from the participating teams. Therefore, both the documents and files may be reviewed and updated over time.

www.euforall3dproject.com

SUPPORTED BY:

Erasmus+
Enriqueciendo vidas, abriendo mentes.



Cofinanciado por
la Unión Europea

The EU FOR ALL project is co-funded by the European Union. The views and opinions expressed in this publication are those of the author(s) only (Interrobotics para humanos SL, on behalf of the EU FOR ALL consortium) and do not necessarily reflect those of the European Union or the Spanish Service for the Internationalisation of Education (SEPIE). Neither the European Union nor SEPIE can be held responsible for them.

PARTNERS:



1. Printing Parameters

- PETG parameters.
- Access to documentation and videos.

2. Tools

- List of materials for assembling the machine.

3. Printable Parts

- Central structure.
- Side supports.
- Cutter.
- Motor structure.
- Spool.
- Filament connector.
- Screen protector.

4. Non-printable Parts

- Hot end support.
- Digital screen.

5. Complementary Activity

Terms of Use and Funding

- Licensing, credits and Erasmus+ co-funding

1 Printig parameters

In this document you will find the files ready to print the different parts of the recycler. Keep in mind that some sections operate at high temperatures; to reduce risks (such as deformation, softening, or premature failure), we will manufacture these parts in PETG, as it offers greater thermal and mechanical resistance than PLA.

In the following table, the basic parameters you should configure on the 3D printer are summarized to ensure consistent results.

Additionally, the table is designed so you can print it, cut it out, and attach it to the recycler, allowing you to keep the settings handy during assembly and use.

PETG Parameters



| | | | |
|--------------|-------------|----------------------|---------|
| Layer Height | 0.2 | Wall | 2 |
| Speed | 70 mm/s | Top / Bottom Layers | 4/3 |
| Temperature | 240° - 260° | Travel Speed | 90 mm/s |
| Infill | 15% | Build Plate Adhesion | No |

👁 Access to Documentation and Videos

In the following icons, you will have access both to the elements in Tinkercad and to the complete recycler playlist, including the four videos covering the parts, assembly, operation, and printing with recycled material. To access them, click on the icons and the link will appear.



List of Materials for Assembling the Machine

The following list includes the tools required for assembling the PET filament recycler, carrying out the project, and ensuring safety. Make sure you have everything ready!

- Screwdrivers of various sizes or Allen keys.
- Gloves.
- Safety goggles.
- Scissors.
- Plastic bottles.
- Recycled cardboard.
- Tempera paints, acrylic paint, markers, tape, pencil, eraser, glue, and other plastic materials.
- Lighter or tool for heating the filament.
- Hairspray for better build plate adhesion.
- Computers with sufficient requirements for the applications used (Canva, Tinkercad, slicer...).
- Computer peripherals such as mice and keyboards.
- 3D printer capable of printing PETG.
- Cutting mat or table protector.
- Initial PETG filament if we want to print the printer parts in different colors.

Printable Parts

Below we present the main parts of the recycler that can be printed and customized. You will also find images of each file in the 3D design platform.

🕒 Central Structure

The central structure houses all the electronics inside. It is not a solid piece, but rather several pieces joined together.

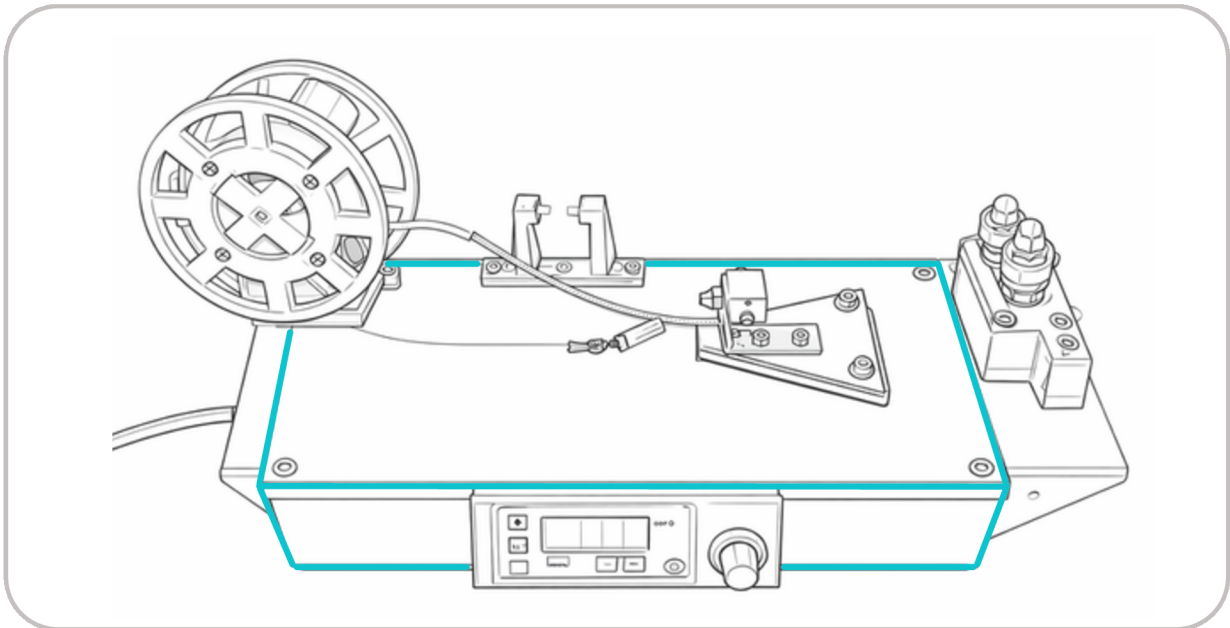

Here we have the 3D models of both parts: the machine support and the top cover.

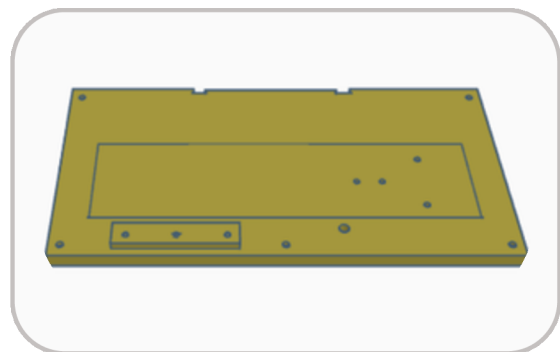
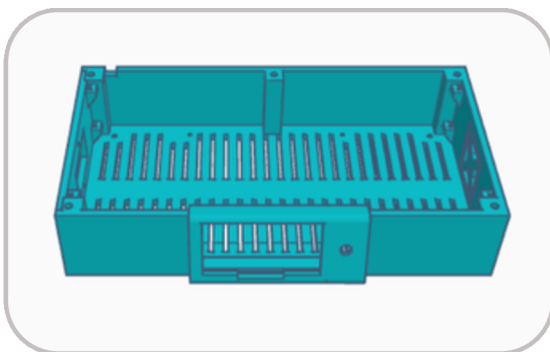

This is how these two parts would look once printed:

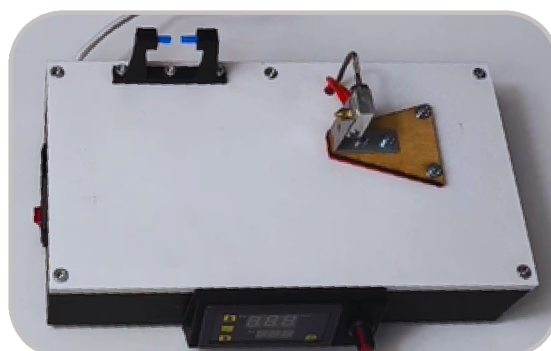

Printable Parts

👁 Side supports

The side supports are adjustable on the sides to facilitate the attachment of the cutter and motor.

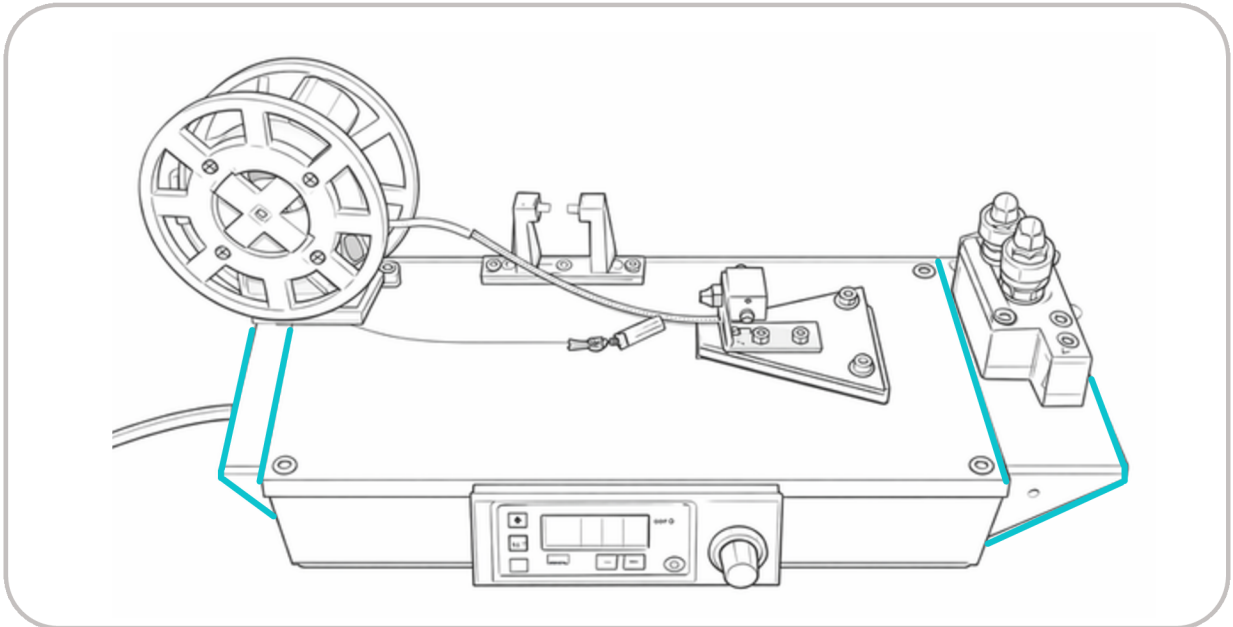

Here are the 3D models of both components: the right support and the left support of the machine.

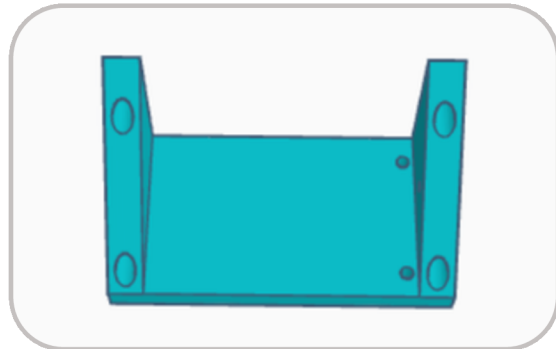
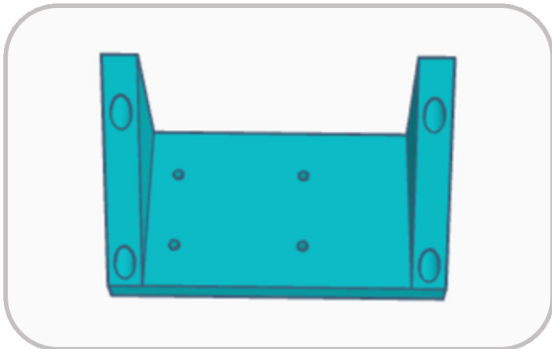

This is how the piece would appear once printed:

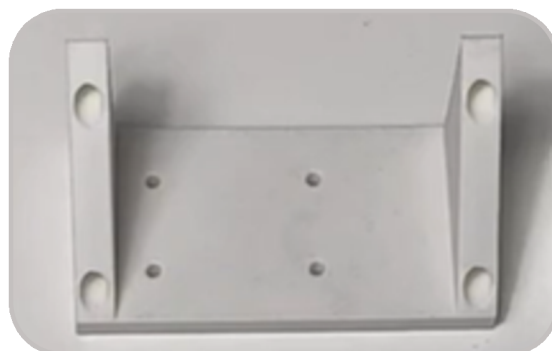

Printable Parts

👁 Cutter

The cutter is positioned at one end of the recycler, serving as the location where we will slice the bottle into a long strip.

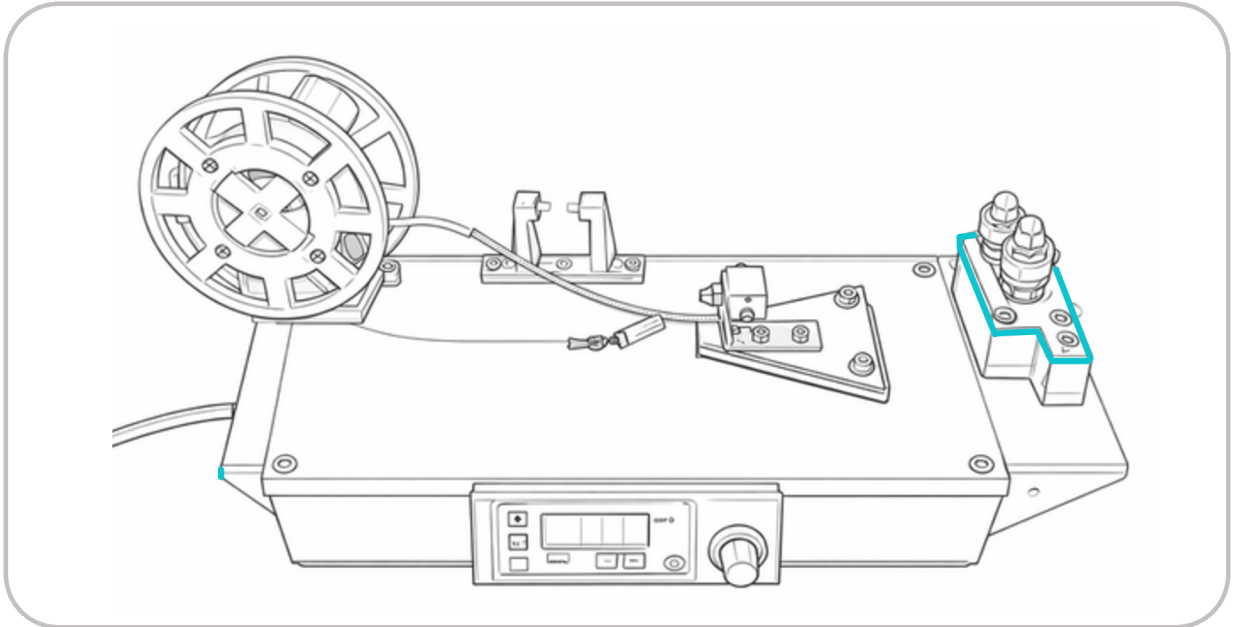

Here is the three-dimensional model of the bottle cutter.

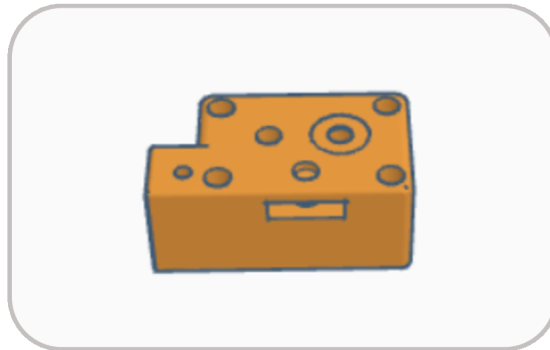

This is how this piece would appear once printed:



Printable Parts

Motor Structure

The motor is situated at the opposite end of the recycler and drives the coil to wind the filament.

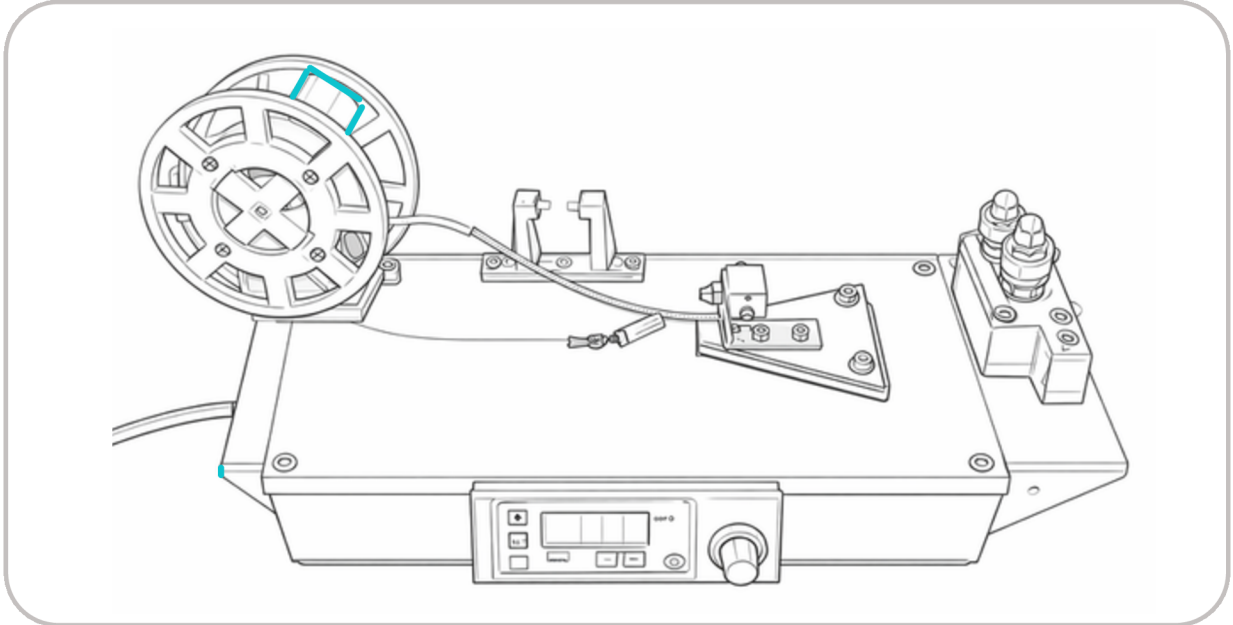

Here is the three-dimensional model of the engine.

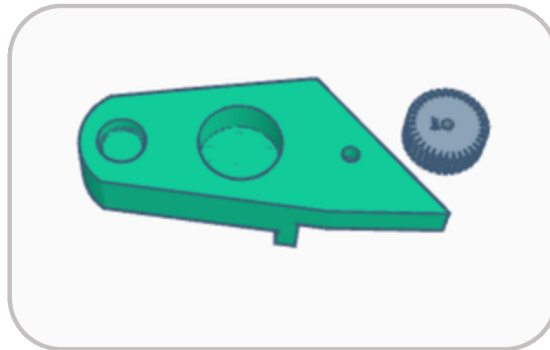

This is how this piece would appear once printed:



Printable Parts

👁 Spool

The spool is affixed to the motor, enabling it to rotate and wind the filament.

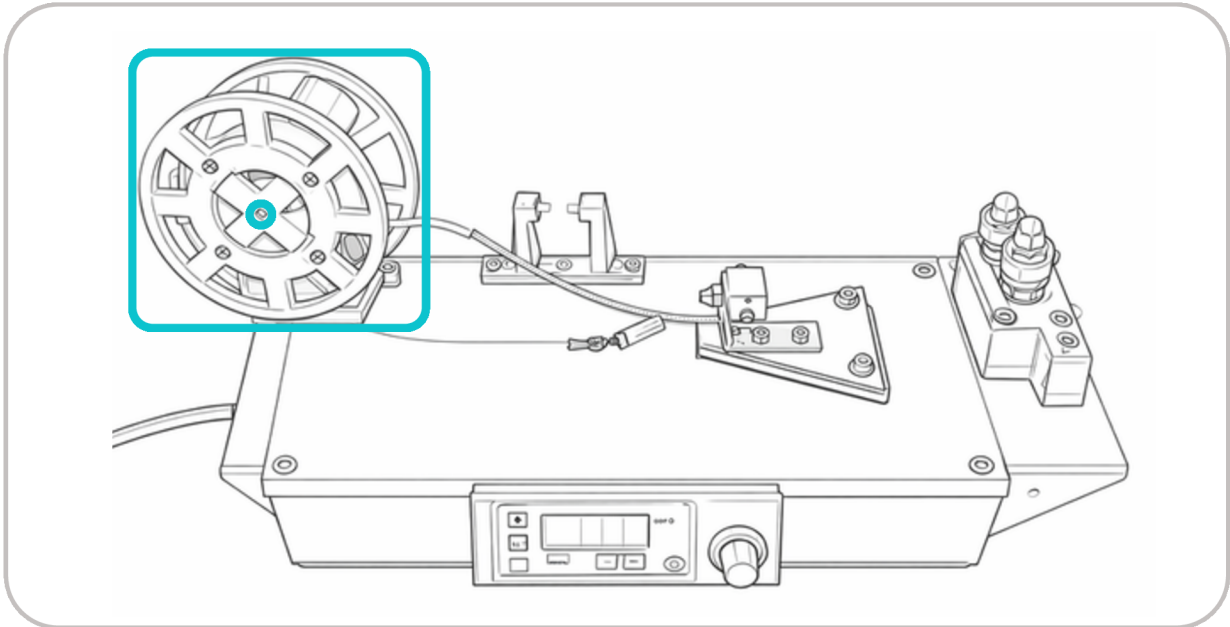

Here is the three-dimensional model of the spool.

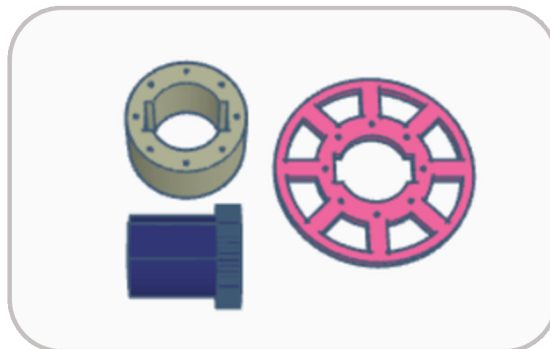

This is how this piece would appear once printed:



Printable Parts

🕒 Filament connector

Filament connector is employed to unite two distinct filament ends, enabling the attainment of increased length or the combination of various colors.

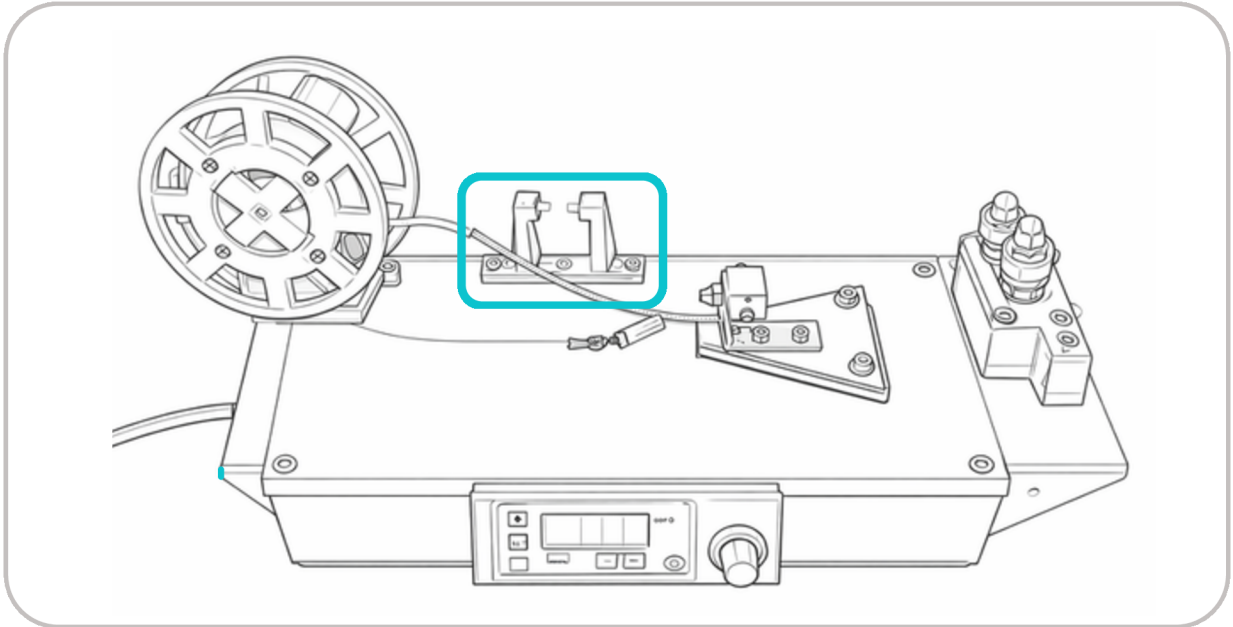

Here is the three-dimensional model of the filament connector.



This is how this piece would appear once printed:

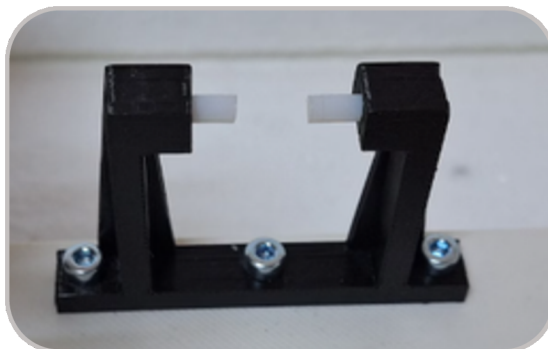

Printable Parts

Screen protector

The screen protector aids in preventing scratches; it is recommended to apply it after use.

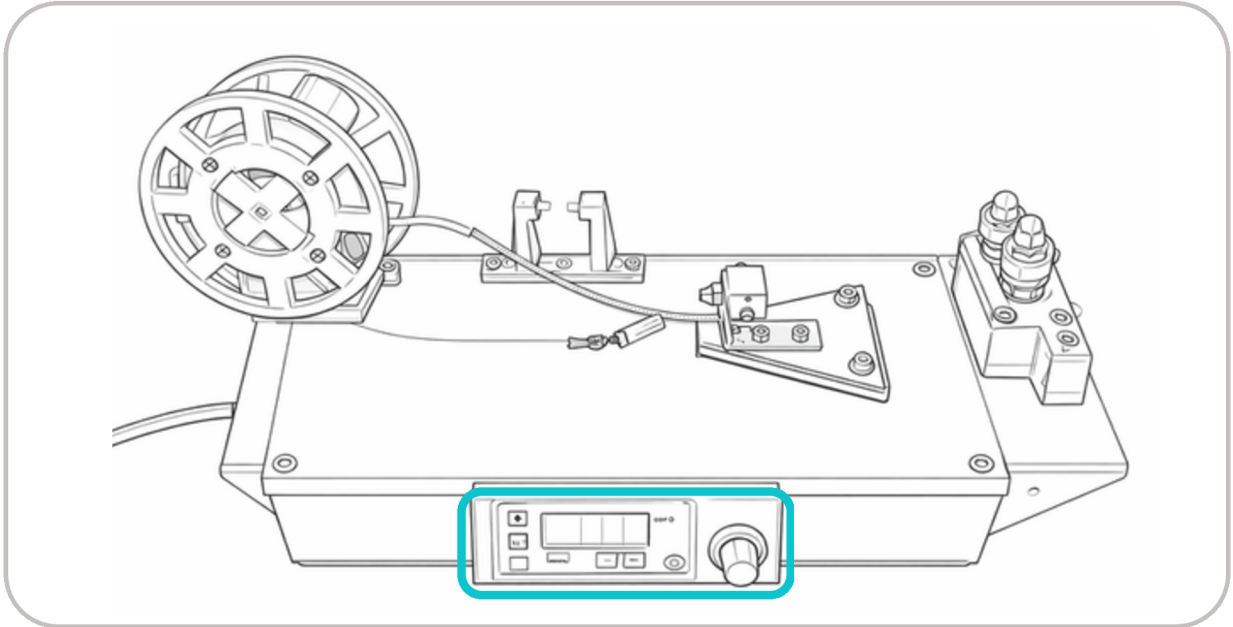

Here is the three-dimensional model of the screen protector.

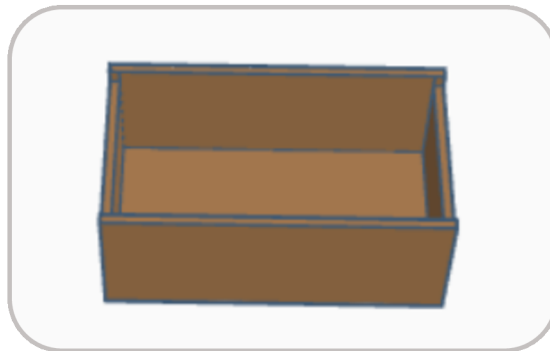

This is how this piece would appear once printed:



Non-printable components

In our recycling facility, we also handle non-printable components, including all items associated with electronics and parts that are unsuitable for printing due to their exposure to high temperatures.

👁 Hot End Support

This component interfaces with screws and anchors that endure elevated temperatures; the piece is pre-anchored and crafted using a laser cutter from wood, though we can also obtain the .STL file if desired.

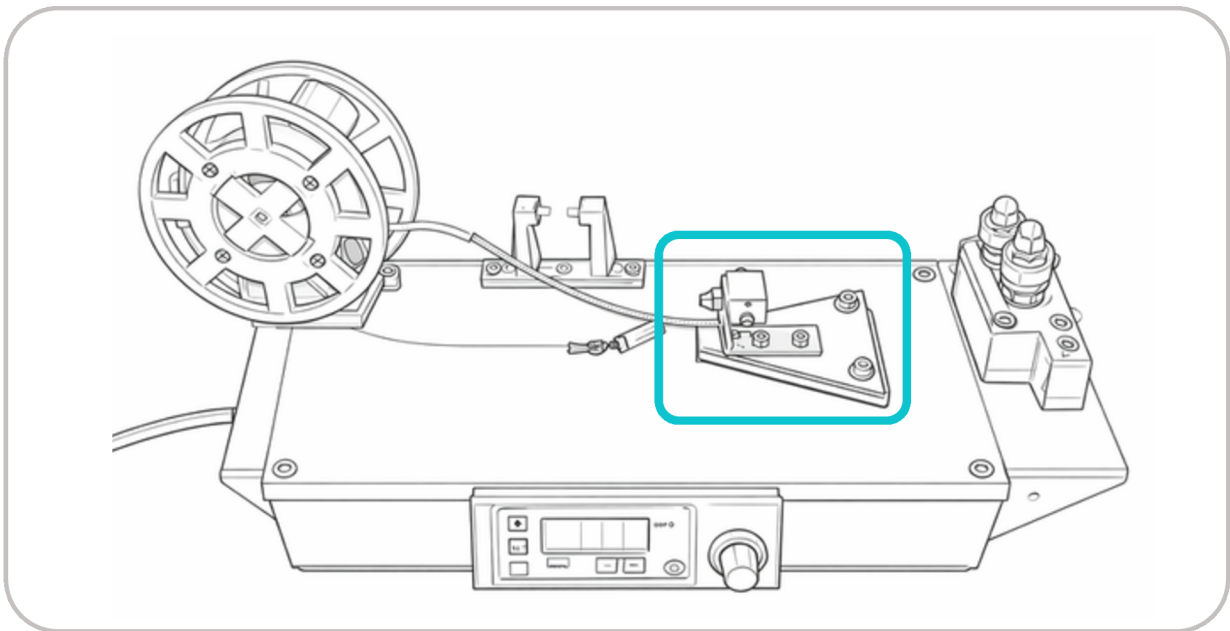

Here is the 3D model of the hotend bracket.

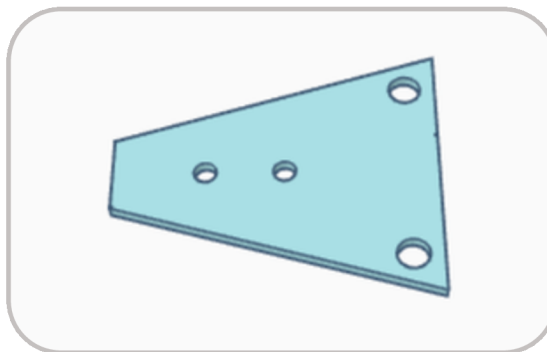

Non-printable components

🕒 Digital screen

This section features a rotary knob for regulating motor speed, accompanied by temperature controls that allow for adjustments in one-degree increments via the "+" or "-" buttons. The "SET" button facilitates temperature increases in 50°C increments.

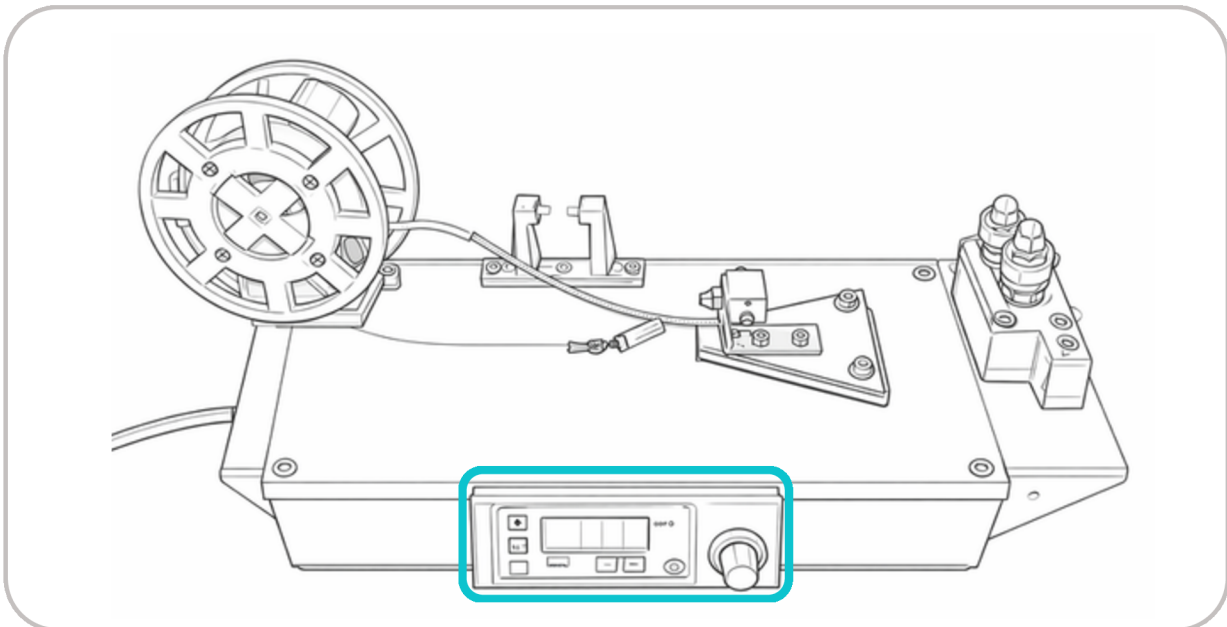

Here we present the display of our recycling machine.



Scan the QR code to observe the functionality of the recycler.

5 Supplementary Activity



Here are the accurate responses; they need not be identical, as some terms may differ. For instance, screen, display controller, or controller would all be acceptable answers.

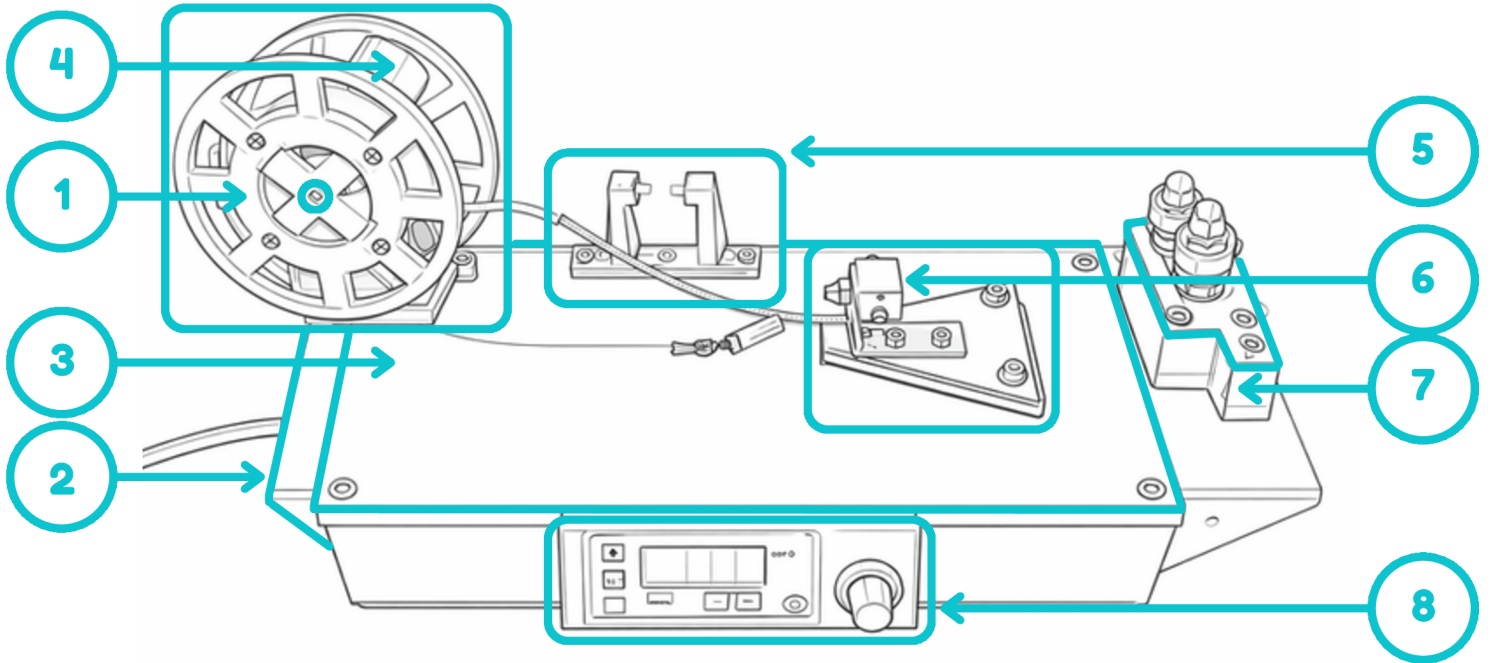

Printable Components of the PET Bottle Recycling Machine

Number and specify the name of each component:

① SPOOL

⑤ FILAMENT CONNECTOR

② SIDE SUPPORT

⑥ HOT END

③ CENTRAL STRUCTURE

⑦ CUTTER

④ MOTOR

⑧ SCREEN

Notes:

5 Complementary Activity



The following box contains the primary components of the recycling machine for identification; the first page features blank boxes for responses, while the subsequent page displays the names for verification of accuracy.

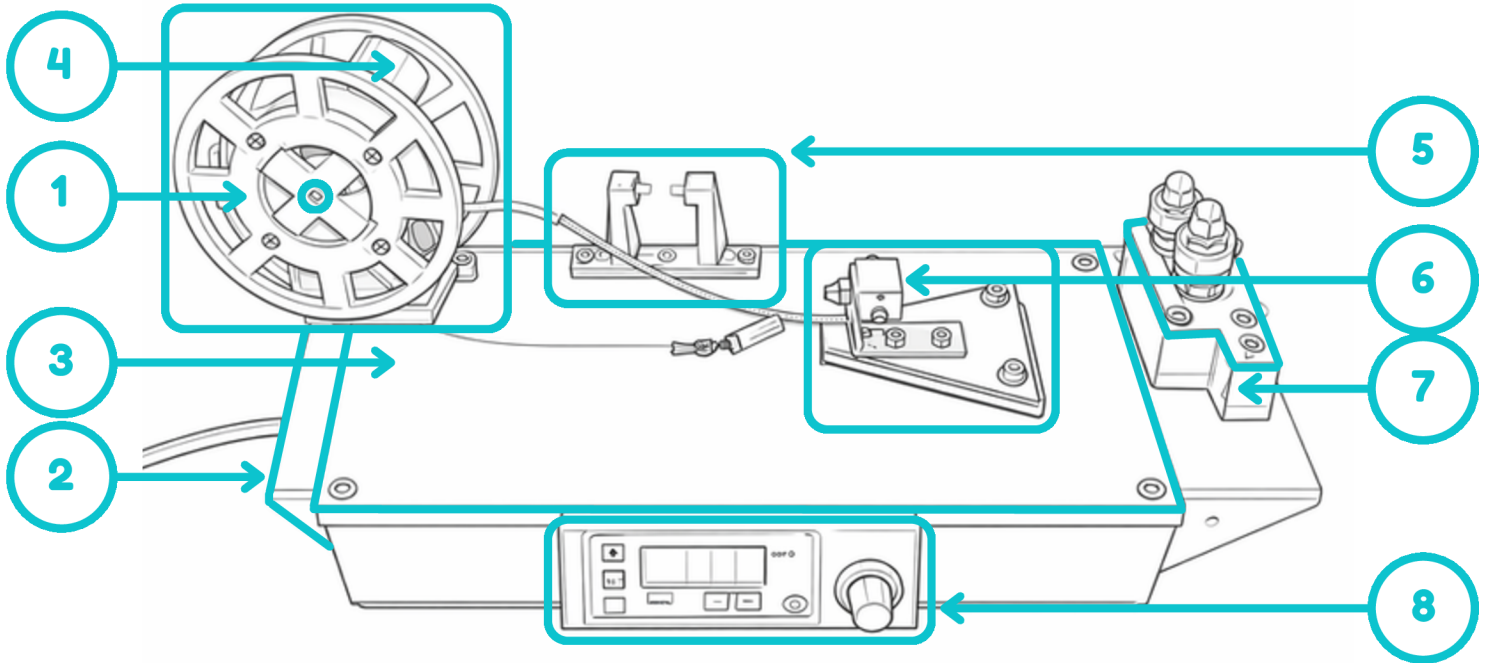

Printable Components of the PET Bottle Recycling Machine

Number and specify the name of each component:

1 NAME

5 NAME

2 NAME

6 NAME

3 NAME

7 NAME

4 NAME

8 NAME

Notes:

Terms of Use and Funding

The educational materials developed within the framework of the EU FOR ALL project, led by the consortium of OBO - We Teach Robotics, have been designed to promote digital inclusion and technological literacy.



These materials aim to provide accessible and engaging learning experiences that foster key competencies in digital skills, problem-solving, and critical thinking. Through interactive and hands-on approaches, the project seeks to empower learners of all backgrounds by equipping them with the necessary tools to navigate an increasingly digital world.

Developed in collaboration with experts in education, technology, and inclusion, these resources reflect the commitment of the EU FOR ALL consortium to innovation in education and the reduction of the digital divide.

Creative Commons License

The educational materials developed within this project are licensed under Creative Commons – Attribution, Non-Commercial, ShareAlike (BY-NC-SA EU).

This means they can be freely used, shared, and adapted, as long as:

- Proper credit is given to the authors and the project.
- They are not used for commercial purposes.
- They are shared under the same license.



For more information about this license, visit [Creative Commons website](https://creativecommons.org/licenses/by-nc-sa/4.0/).

Disclaimer of Liability Clause

The EU FOR ALL project is co-funded by the European Union. The views and opinions expressed in this publication are those of the author(s) only (Interrobotics para humanos SL, on behalf of the EU FOR ALL consortium) and do not necessarily reflect those of the European Union or the Spanish Service for the Internationalisation of Education (SEPIE). Neither the European Union nor SEPIE can be held responsible for them.

Co-financing Emblem

This material has been developed within the framework of the Erasmus+ Programme and has received co-funding from the European Union.



**Co-funded by
the European Union**

Terms of Service and Financing

The educational resources created under the EU FOR ALL project, spearheaded by the OBO - We Teach Robotics consortium, aim to foster digital inclusion and enhance technological literacy.



These materials are designed to offer accessible and engaging learning experiences that cultivate essential competencies in digital skills, problem-solving, and critical thinking. By employing interactive and hands-on methodologies, the project aspires to empower learners from diverse backgrounds by providing them with the requisite tools to successfully navigate an ever-evolving digital landscape.

Developed in partnership with specialists in education, technology, and inclusivity, these resources embody the EU FOR ALL consortium's dedication to educational innovation and the mitigation of the digital divide.

Creative Commons License

The educational materials created for this project are licensed under Creative Commons - Attribution, Non-Commercial, ShareAlike (BY-NC-SA EU).

This indicates that they may be utilized, shared, and modified without restriction, provided that:

Proper acknowledgment is provided to the authors and the project.

- They are not utilized for commercial purposes.
- They are distributed under the same license.



For additional information regarding this license, please visit the [Creative Commons website](https://creativecommons.org/licenses/by-nc-sa/4.0/).

Disclaimer of Liability Provision

The EU FOR ALL project receives co-funding from the European Union. The views and opinions articulated in this publication are solely those of the author(s) (Interobotics para humanos SL, representing the EU FOR ALL consortium) and do not necessarily represent the positions of the European Union or the Spanish Service for the Internationalisation of Education (SEPIE). Neither the European Union nor SEPIE can be held accountable for these views.

Co-financing Emblem

This material has been created under the auspices of the Erasmus+ Programme and has been co-funded by the European Union.



**Co-funded by
the European Union**